	SPECIFICATION	Model No.	CRT-288K
		Date	2013/06/22
Manual Insertion Card Reader		Ver.	1.0
		Page	1/11

# **CRT-288-K001**

## **MANUAL INSERTION CARD READER PRODUCT SPECIFICATION**





## SPECIFICATION

Model No.

CRT-288-K

Date

2013/06/22

Manual Insertion

Ver.

1.0

Card Reader

Page

2/11

## Revisions

Version	Date	Content
1.0	2013.06.22	Initial release

CREATOR



## SPECIFICATION

Manual Insertion  
Card Reader

Model No.

CRT-288-K

Date

2013/06/22

Ver.

1.0

Page

3/11

Thanks for selecting products of Creator-China

Please read the manual carefully before using

CRT-288-K001 serial mode :

CRT-288-K001-HEAY CRT-288-K001-HQAY

CRT-288-K001-EQAY CRT-288-K001-EEAY

CRT-288-K001-GQAY CRT-288-K001-GEAY

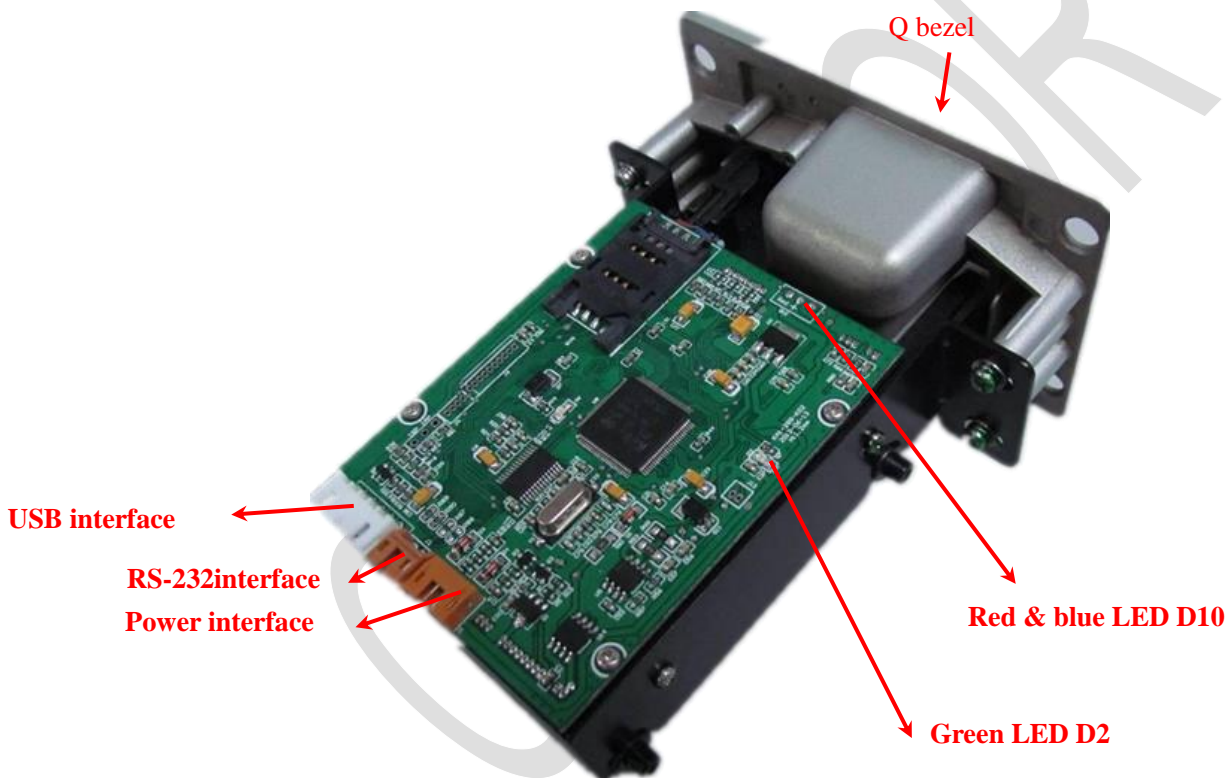

### Warning:

1. Any DC power over 7Voltage must be prohibited, or CRT-288-K will be damage.



## SPECIFICATION

Model No.

CRT-288-K

Date

2013/06/22

Manual Insertion  
Card Reader

Ver.

1.0

Page

4/11

# CONTENTS

## 1. General View

CRT-288-K is a manual insertion card reader with controlled card latch and performs the following features:

- Read ISO standard magnetic stripe cards, RFID cards and IC card
- Electric card latch and release function. Card could be retrieved once latched if you pull by over 15 N of pulling force,
- RS232/USB interface (automatically detect interface)
- Agile magnetic stripe reading type: Read when insert/withdraw and uploaded passively /actively
- Long Life time (500,000 times)

## 2. Model Number Specification and Accessories

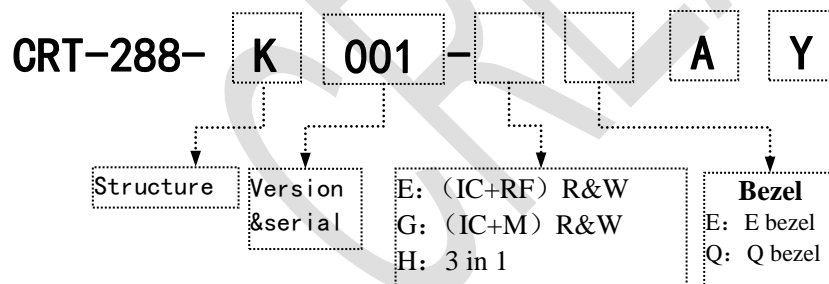

### 2.1 BEZEL:



E Bezel



Q Bezel

	SPECIFICATION	Model No.	CRT-288-K
		Date	2013/06/22
	Manual Insertion Card Reader	Ver.	1.0
		Page	5/11

## 2.2 Standard accessory for RS232 interface

Item	Model	Qty	Notes
4PIN Power Cable	L14-333-153	1	4PIN connector, Length: 1.5m, length 1.5m (red and yellow wire for each and 2 black wire)
3pin serial cable	L10-006-163	1	3PIN connector, length: 1.6m, brown red and orange

2.2.1 4PIN power cable, shown as below picture:

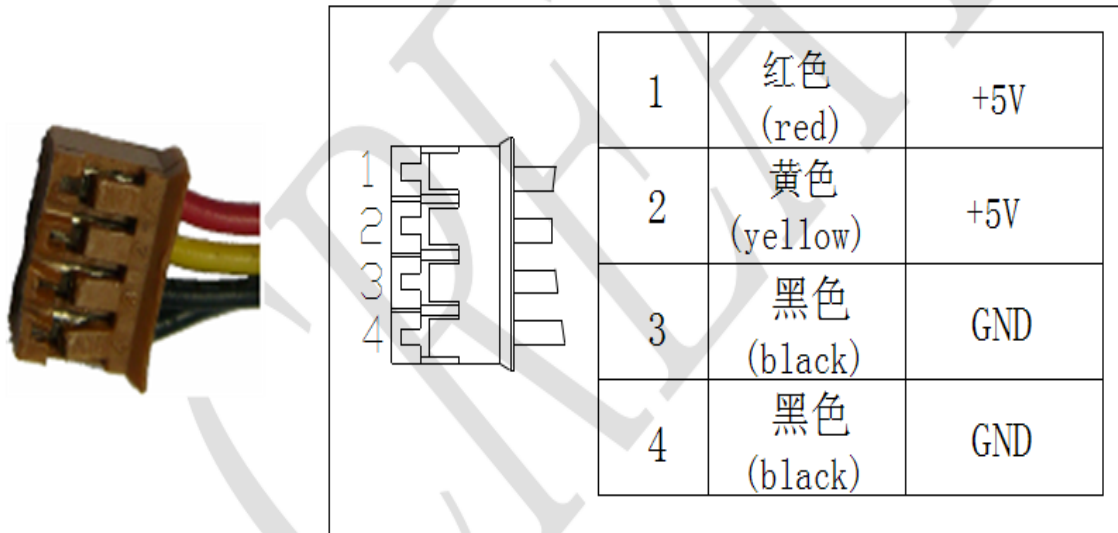

2.2.2 RS232 serial cable

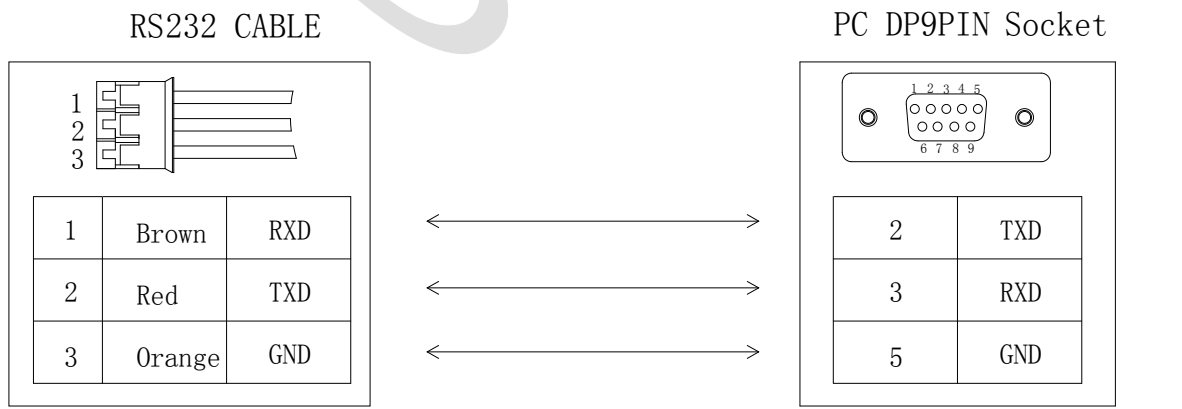



## SPECIFICATION

Model No.

CRT-288-K

Date

2013/06/22

Manual Insertion  
Card Reader

Ver.

1.0

Page

6/11

### 2.3 Standard accessory for USB interface

Item	Model	Qty	Notes
USB Cable	L10-008-153	1	5 PIN, length 1.5M

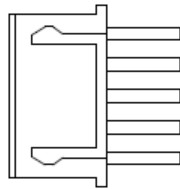
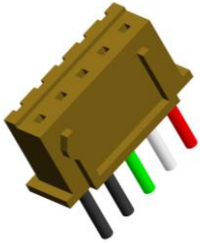

1	RED	USB_VCC
2	WRITE	USB_DM
3	GREEN	USB_DP
4	BLACK	USB_GND
5	BLACK	USB_GND



## SPECIFICATION

Model No.

CRT-288-K

Date

2013/06/22

Ver.

1.0

Page

7/11

Manual Insertion  
Card Reader

### 3. Technical Specification

- **Power**

DC 5V±5% or USB

- **Power Consumption**

Work current: <200 mA

- **Interface**

RS232 or USB Interface (Automatically detect)

- **Card Specification**

Width: 53.92~54.18 mm

Length: 85.47~85.90 mm

Thickness: 0.76mm ± 0.08 mm

- **Net Weight**

Approx. 240g (Excluding accessory and package)

- **Dimension**

Refer to dimension drawing

- **Reliability**

A. Vibration: No negative effort on all functions under normal condition after exposed 15min. each on X, Y and Z directions of 2mm amplitude, from 5 to 50Hz/min vibrate and acceleration is 2m/S<sup>2</sup> (0.2G).

B. Shock: No negative effort on all functions under normal condition after shock one time on X, Y and Z directions of 294M/S<sup>2</sup>, 11ms peak acceleration shock.

- **Life time**

Magnetic head 500,000 times Min

IC card contact carrier and contact: 300,000 times Min

Latch Mechanism: 500,000 times Min

- **Error Rate**

Magnetic card: <1/1,000 ( 15~25°C, 35~60%RH, perfect and standard card )

IC card: <1/1,000, ( 15~25°C, 35~60%RH, perfect and standard card )

RFID card: <1/10,000, ( 15~25°C, 35~60%RH, perfect standard card )

- **Abnormal card**

Allowance of card warp: 2mm max.

- **MTBF**

>1 X10<sup>5</sup> hrs ( Electronic components only )

Note: 250 times/day, 25 days/month, 300 hrs/month



## SPECIFICATION

Model No.

CRT-288-K

Date

2013/06/22

**Manual Insertion  
Card Reader**

Ver.

1.0

Page

8/11

- **Environment**

Operation: 0°C-50°C, 0~90% RH ( non-condensing )

Storage: -25°C~80°C, 0~95% RH ( non-condensing ,dried before usage )

Normal environment: 15~25°C, 35~60%RH

- **IC card standard**

ISO7816 standard certified, EMV2000 Level1, PBOC3.0 (WITH CERTIFICATE)

e.g. (AT24C01, 24C02, 24C256, SLE4447, SLE4428, CPU T=0/T=1)

- **Magnetic card standard**

Physical characteristics: ISO7810 and 7811 standard compliant

Card dimensions: SO ISO7810ID-1- type card compliant

Embossing: ISO7811-1, ISO7811-3 compliant

Recording format: ISO7811-2, ISO7811-4, ISO7811-5, ISO7811-6 complaints

- **RFID card standard**

ISO14443-3 compliant (TYPE A: e.g. S50,S70,UL etc )

ISO14443-4 compliant (TYPE A CPU, TYPE B CPU e.g. Mifare plus, Mifare DesFire etc)

- **RoHS Compliance**



	SPECIFICATION	Model No.	CRT-288-K
		Date	2013/06/22
	Manual Insertion Card Reader	Ver.	1.0
		Page	9/11

## 6. Maintenance

After long time usage, transportation mechanism would wear and tear, dust on sensor, magnetic head, IC card contact will influence the performance of module, so it should be maintained on a constant basis.

Detail instruction is as following:

- Use a cleaning card with alcohol to clean magnetic head by pulling and inserting in card reader for several times.
- Insert a cleaning card with alcohol and execute auto test IC card several times to clean IC card contact.
- Periodic maintenance: Maintaining the module (Magnetic head, IC contact, Mechanism) every 20,000 cycle is recommended.  
( One cycle: card in and card out )

Different components' maintenance is as following:

- 1) IC card contact maintenance: Insert an IC card with alcohol; execute auto test IC card
- 2) Magnetic head maintenance: Insert/pulling a cleaning card with repetition.

## 7. Cautions

- Make sure power is disconnected before maintenance to prevent the device from damage.
- Oil will dramatically influence card reader's performance, please keep the device from oil absorbent adhesive.
- Active/passive data upload method for magnetic stripe card reading has been designed
- Setting magnetic stripe card reading method: Read when insertion or pulling, set reading mode in DEMO.
- Keep anything away from magnetic head and its cable.
- IC card insertions direction: when cards is inserted from the front, IC chip faces up, the end with IC chip
- Magnetic card insertion direction: Magnetic stripe face down and keep it to the right



## SPECIFICATION

Manual Insertion  
Card Reader

Model No.

CRT-288-K

Date

2013/06/22

Ver.

1.0

Page

10/11

### 8. Reference Documents

- 1) DLL Specification: CRT-288-K001.DLL
- 2) DLL: CRT-288 DLL. rar
- 3) Communication Protocol: CRT-288 V10 Communication Protocol. PDF

### 9. Dimensions Drawing

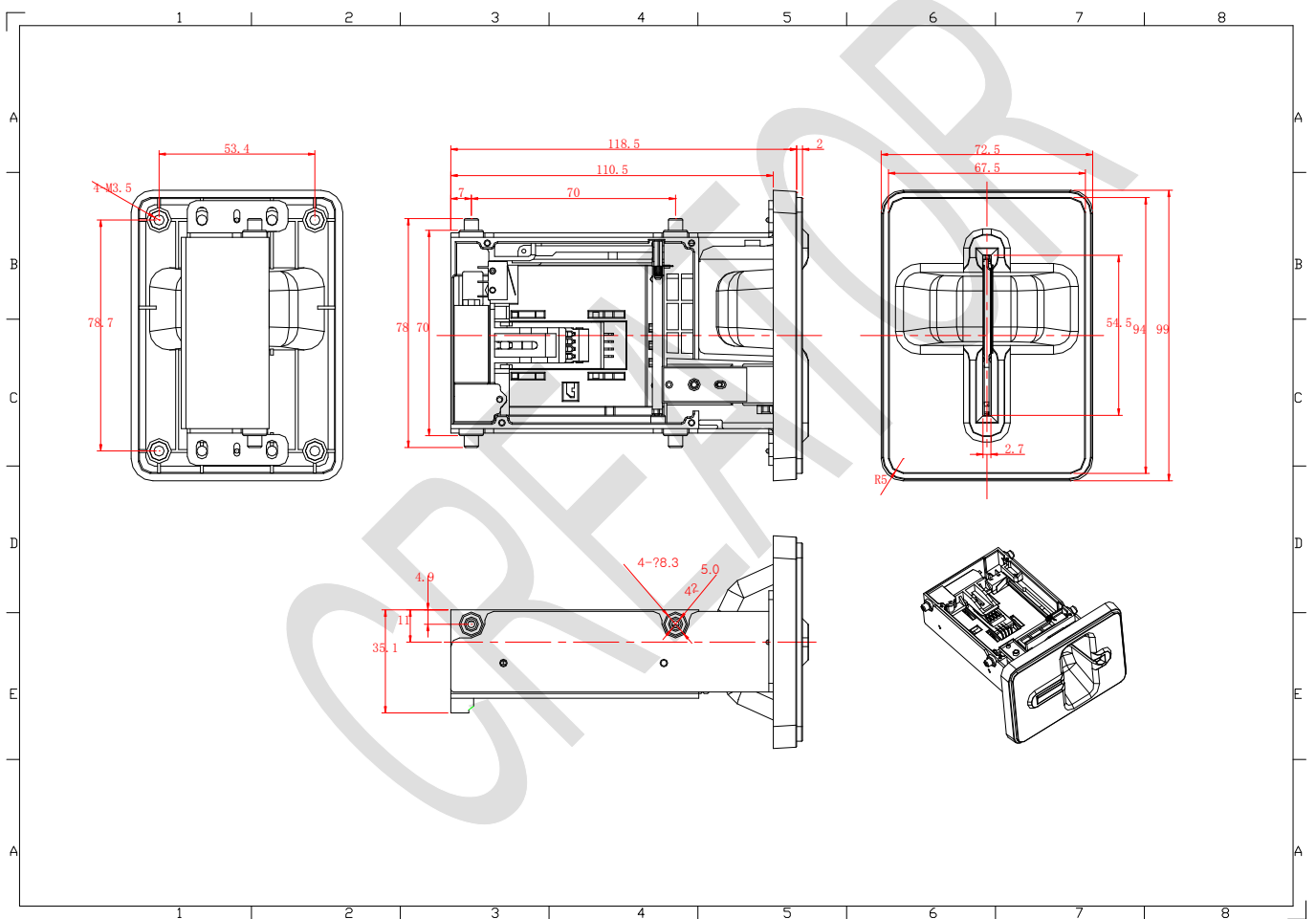

CRT-280 E Bezel Dimension



# SPECIFICATION

## Manual Insertion Card Reader

Model No.

CRT-288-K

Date

2013/06/22

Ver.

1.0

Page

11/11

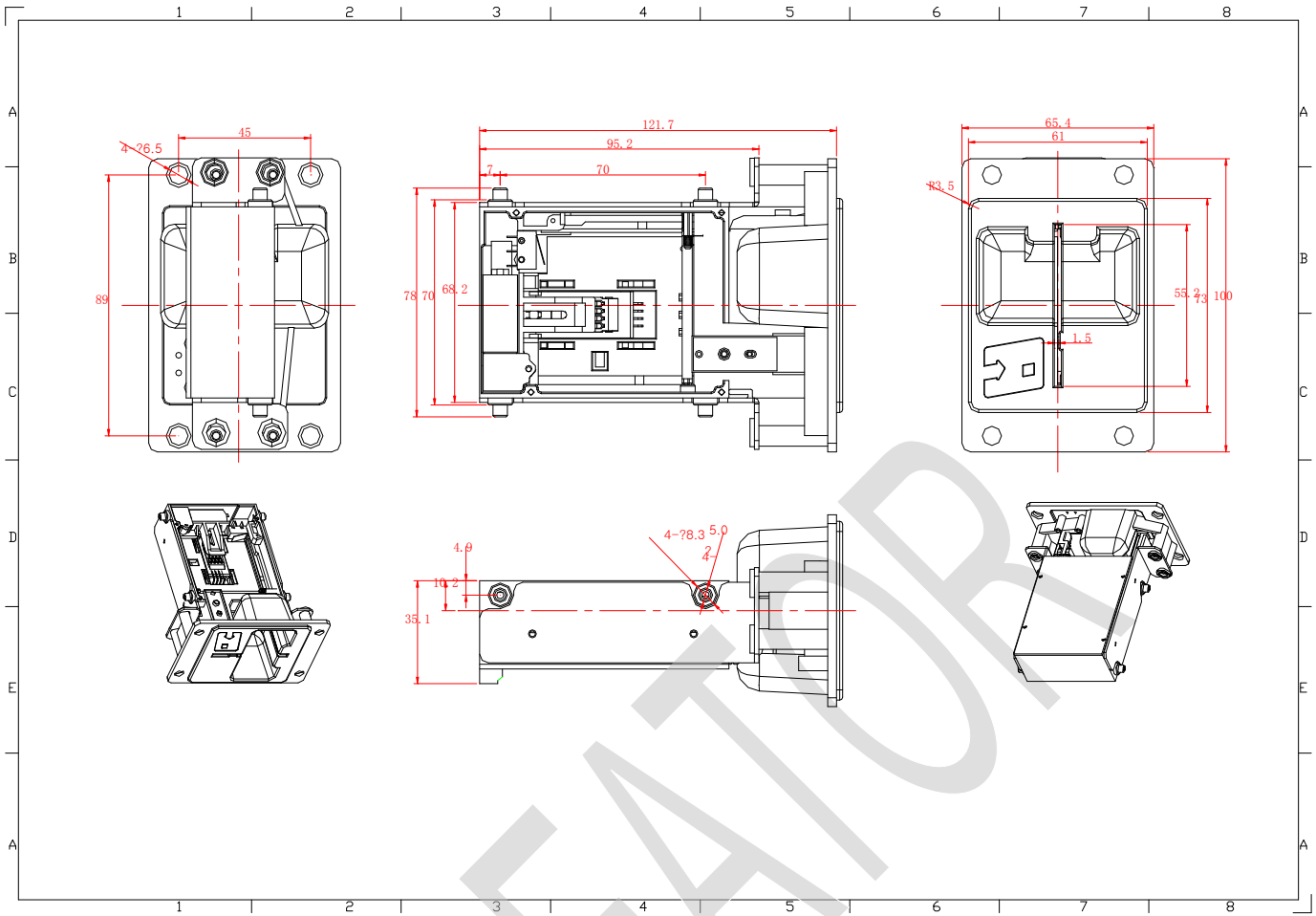

**CRT-280 Q Bezel Dimensions**