	SPECIFICATION	Model No.	CRT-541
		Date	2010/01/10
	Card Dispenser	Version	1.0

CRT-541 Card Dispenser Machine

Version 1.0

PRODUCT SPECIFICATION



CREATOR (CHINA) TECH CO., LTD.

·2F, M-10 Building, Center Area, Hi-tech Industrial Park, Shenzhen Guangdong China

·TEL: +86 755 26710691 FAX: +86 755 26710105

·Http://www.china-creator.com

	SPECIFICATION	Model No.	CRT-541
		Date	2010/01/10
	Card Dispenser	Ver.	1.0

CONTENTS

1.	OVERVIEW.....	1
2.	PRODUCT MODULE NUMBER SPECIFICATION.....	2
3.	GENERAL PECIFICATION.....	3
4.	<i>CRT-541 DESIGN SPECIFICATION.....</i>	4
4.1	CARD THICKNESS ADJUSTMENT.....	4
4.2	STRUCTURE AND DIMENSION DRAWINGS.....	5
4.3	RS-232 COMMUNICATION MODE.....	6
4.31	RS-232 COMMUNICATION INTERFACE.....	6
4.32	FRAME BIT DETAILS.....	6
4.33	FRAME STRUCTURE DIAGRAM.....	6
4.4	TRANSMISSION DATA PACKAGE CHARACTERS.....	7
4.4.1	DEFINITION OF CONTROL CHARACTER.....	7
4.4.2	DATA PACKAGE STRUCTURE.....	7
4.4.2.1	FROM HOST TO UNIT.....	7
4.4.2.2	FROM UNIT TO HOST.....	7
4.4.3	COMMAND LIST.....	8
4.4.4	WORKING STATUS RESPONSE DATASHEET.....	8
4.4.5	STACKER STATUS RESPONSE DATASHEET.....	9
4.5	TTL COMMUNICATION MODE.....	9
5.	GENERAL COMMUNICATION PROCESS.....	11
5.1	TYPICAL COMMUNICATION PROCESS BETWEEN HOST & UNIT.....	12
5.1.1	NORMAL PROCESS OF DISPENDING.....	12
5.1.2	RECEIVED DISPENSING COMMAND.....	12
5.1.3	RECEIVED DISPENSING COMMAND WHILE DISPENSER ERROR.....	12
6.	MULTI-UNIT COMMUNICATION SETTING.....	13
6.1	SKETCH MAP OF MULTI-UNIT PCB.....	13
6.2	DIP SETTING OF UNIT ADDRESS.....	14
7.	MAINTENANCE AND CAUTIONS.....	15
7.1	MAINTENANCE.....	15
7.2	CAUTIONS FOR SAFE USE.....	15
7.3	WARRANTY.....	16

	SPECIFICATION	Model No.	CRT-541
		Date	2010/01/10
	Card Dispenser	Ver.	1.0
		Page	

Revision Log

Version	Revision Time	Content
1.0	2010.1.25	First Release
1.0	2010.8.6	Add TTL specification

	SPECIFICATION	Model No.	CRT-541
		Date	2010/01/10
	Card Dispenser	Ver.	1.0
		Page	1/196

1. OVERVIEW

CREATOR (CHINA) CRT-541 card dispenser is upgraded from CRT-540. It performs more stable and reliable but is compatible with CRT-540 in all aspects, including communication protocol, mounting holes position and so on. In addition, CRT-541 has the following features:

- Prevent 2 cards dispensing.
- Paper card dispensing design.
- Easy adjustment of card thickness.
- Easy card loading & maintenance.
- Support ISP downloads on-line.
- Support multi-units communication.
- Card stacker empty and pre-empty detection.
- Pre-Card dispensing function.
- Iron-Block available to fit.
- RoHS standard compliant.

	SPECIFICATION	Model No.	CRT-541
		Date	2010/01/10
	Card Dispenser	Ver.	1.0
		Page	2/16

2. Product Module Number Specification

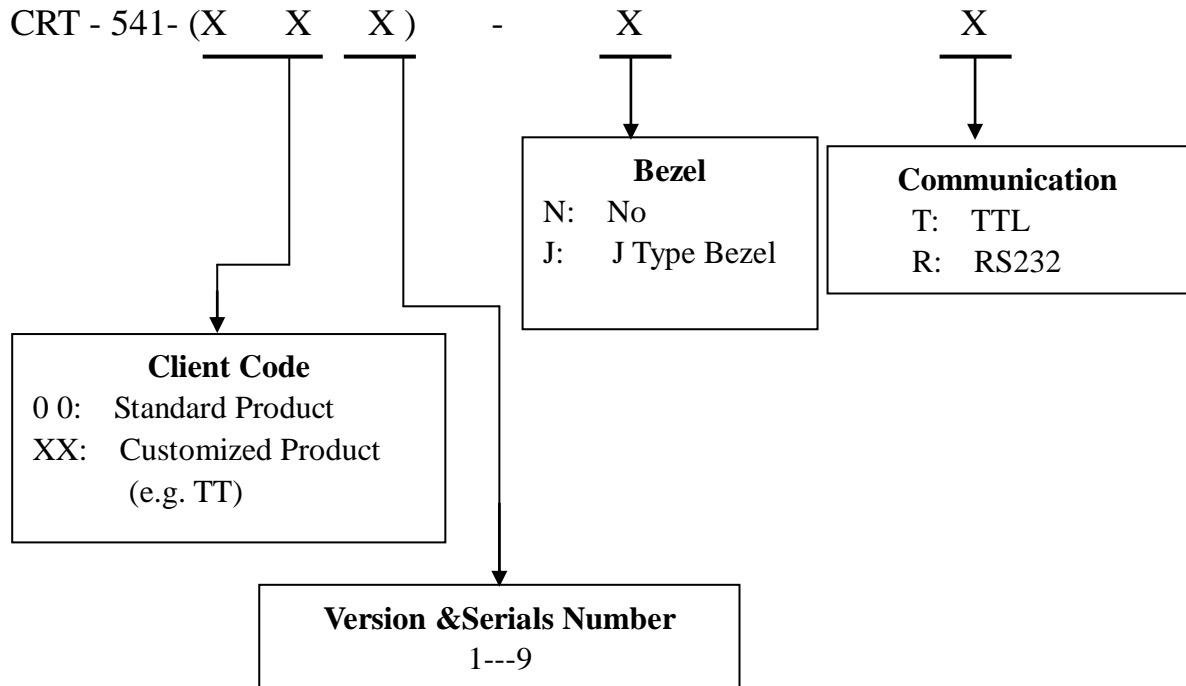

Notes: J Type bezel can't support continuous card dispensing.

NOTE: CRT-541 optional stackers:

Extra-long stacker (285PCS): CRT-500-TCZ (300pcs, 0.76 standard cards)
 Long stacker (170PCS): CRT-500-CKZ (170pcs, 0.76 standard cards)
 Short stacker (60PCS): CRT-500-DKZ (60pcs, 0.76 standard cards)
 TTL connect wire: CRT-500-CB1
 Com wire for extension: CRT-500-CB2 (25cm) CRT-500-CB3 (100cm)

	SPECIFICATION	Model No.	CRT-541
		Date	2010/01/10
	Card Dispenser	Ver.	1.0
		Page	3/16

3. General Specification

- **Power Supply**
DC 24V $\pm 5\%$
- **Current Consumption**
Static Current: 0.1A
Peak Current during Operation: 1.5A
Normal Current Condition: 800mA
- **Card Feeding-Out Speed**
> 1Cards/s
- **Communication Interface**
RS232C, TTL (customized)
- **Card Dimensions**
Size: 55mm \times 86mm
Thickness: $\geq 0.20\text{mm}$ ($\geq 1.2\text{mm}$ require customization)
Ex-work standard card thickness is 0.8 mm
- **Weight**
2.0 Kg Approx.
- **Dimensions**
Refer to 4.2 Structure and Dimension Drawings
- **Card Stacking Capacity**
120pcs in case of 0.76mm standard card
(Available to set to 500pcs max)
- **Card Pre-Empty Detection**
7~50pcs ± 2 pcs (Default setting: 15pcs)
- **Environmental Condition**
Operation: 0~50°C 0~90% RH (Without Condensing)
Storage: -10~75°C 0~90% RH (Without Condensing)
- **Life Time**
500,000 times
(In the condition: 20 $\pm 5\%$, 35~60%RH, $\leq 1\text{pcs/min}$)

	SPECIFICATION	Model No.	CRT-541
		Date	2010/01/10
	Card Dispenser	Ver.	1.0
		Page	4/16

4. CRT-541 Design Specification

4.1 Card Thickness Adjustment

CRT-541 makes it more accurate and convenient to dispense the cards in different thickness via rotating the turn-knob to different gear position so as to adjust the gap between the upper and lower transmitting wheels, which can eliminate the inconvenient and inaccurate gap adjustment defects. With this feature, CRT-541 is quite suitable for the unattended vending devices to dispense various cards of distinct thickness.

There are several steps to adjust the thickness of cards:

1. Confirm the thickness of cards (Raised type character are not involved in)
2. Push the turn-knob and turn around to the graduation pointed by the red arrow. Seeing pictures below.
3. Make sure the adjustment on the right position by insert cards from stacker. (Inserting one card from stacker will be smooth and two cards simultaneously from behind can be impossible)

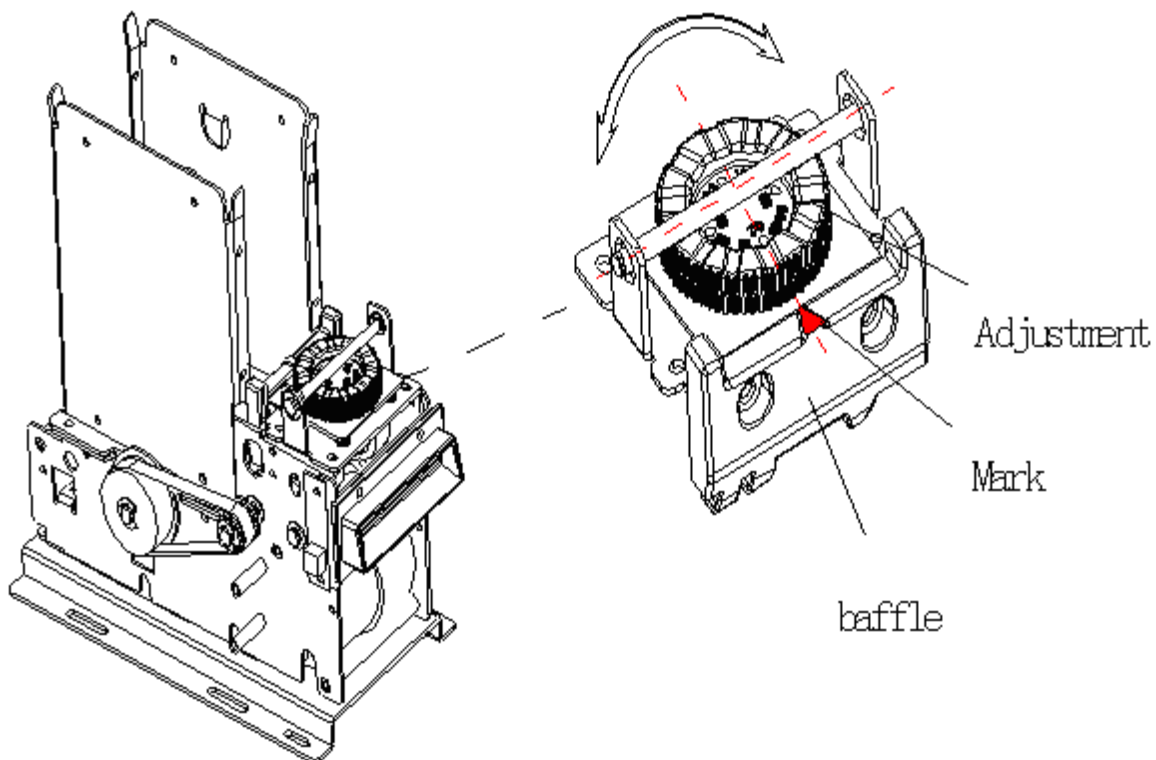

	SPECIFICATION	Model No.	CRT-541
		Date	2010/01/10
	Card Dispenser	Ver.	1.0
		Page	5/16

4.2 Structure And Dimension Drawings

The following diagram show the structure and dimension

1. CRT-541 (No bezel)

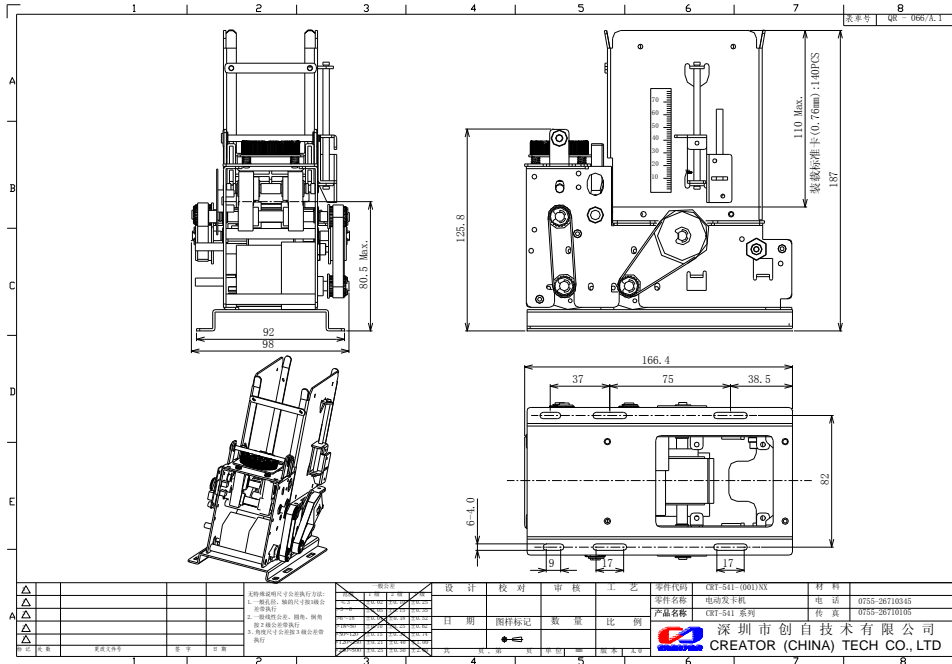

2. CRT-541 (Have bezel)

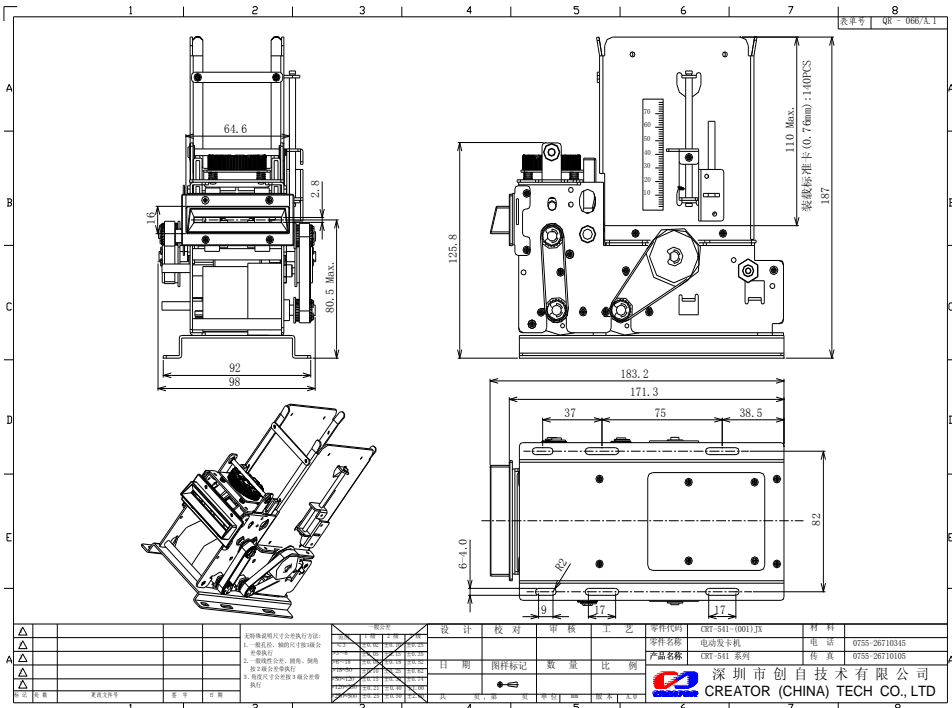

	SPECIFICATION	Model No.	CRT-541
		Date	2010/01/10
	Card Dispenser	Ver.	1.0
		Page	6/16

4.3 RS-232 Communication Mode

4.31 RS-232 Communication Interface

Baud rate (BPS) : 9600 bps
 Communication type : Asynchronous communication
 Transmit type : Half duplex

4.32 Frame Bit Details

Start bit : 1 bit
 Data bit : 8 bits
 Parity bit : None
 Stop bit : 1 bit

4.33 Frame Structure Diagram

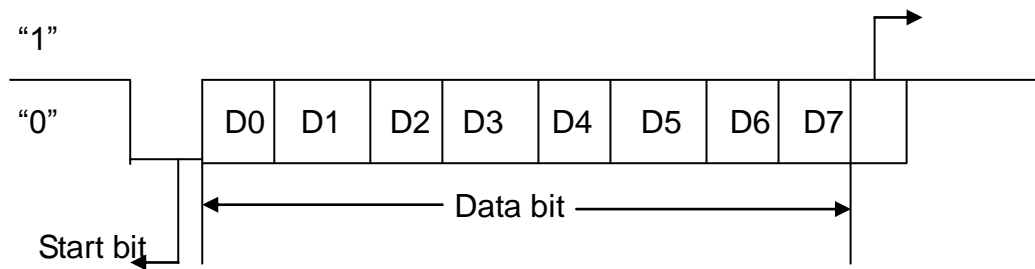

	SPECIFICATION	Model No.	CRT-541
		Date	2010/01/10
	Card Dispenser	Ver.	1.0
		Page	7/16

4.4 Transmission Data Package Characters

4.4.1 Definition of Control Character

- S T X: 0X02 Start character of data package.
 E T X: 0x03 End character of data package.
 A C K: 0x06 Positive acknowledgement character of unit.
 N A K: 0x15 Negative acknowledgement character of unit.

4.4.2 Data Package Structure

4.4.2.1 From Host To Unit (Total 7 Bytes in Length)

STX	Dispenser Address High Byte	Dispenser Address Low Byte	Command High Byte	Command Low Byte	ETX	BCC
-----	-----------------------------	----------------------------	-------------------	------------------	-----	-----

Notes:

- (1) BCC is the sum of XOR, calculate method as follow:
 $BCC = \text{STX} \wedge \text{dispenser address high byte} \wedge \text{dispenser address low byte} \wedge \text{command high byte} \wedge \text{command low byte} \wedge \text{ETX}$ (“ \wedge ” means XOR)
- (2) Data package transfer by ASCII
- (3) Find command in Command list.
- (4) Data in below table are valid value of address, and all of them are character type.

'00'	'01'	'02'	'03'	'04'	'05'	'06'	'07'
'08'	'09'	'10'	'11'	'12'	'13'	'14'	'15'

4.4.2.2 From Unit To Host (Total 7 Bytes in Length)

STX	Dispenser Address High Byte	Dispenser Address Low Byte	Working Status Response Byte	Stacker Status Response Byte	ETX	BCC
-----	-----------------------------	----------------------------	------------------------------	------------------------------	-----	-----

Notes:

- (1) Find working status response byte in Working status response datasheet.
- (2) Find stacker status response byte in Stacker status response datasheet.
- (3) Data in below table are virtual value of address, and all of them are character type

'00'	'01'	'02'	'03'	'04'	'05'	'06'	'07'
'08'	'09'	'10'	'11'	'12'	'13'	'14'	'15'

	SPECIFICATION	Model No.	CRT-541
		Date	2010/01/10
	Card Dispenser	Ver.	1.0
		Page	8/16

4.4.3 Command List

The following table shows command list.

Command	Code	Function
Dispensing card (Card-out address)	'D C'(0x44 0x43)	Dispensing card out of the bezel
Enquiry	'A P'(0x41 0x50)	Check the status of dispenser
Reset	'RS' (0x52 0x53)	Reset command
Pre-dispensing valid	'IP' (0x49 0x50)	Permit card pre-dispensing
Pre-dispensing invalid	'IE' (0x49 0x45)	Forbid card pre-dispensing
Baud rate setting	'B0'(0X42 0X30) 'B1'(0X42 0X31) 'B2'(0X42 0X32) 'B3'(0X42 0X33) 'B4'(0X42 0X34) 'B5'(0X42 0X35)	'B0':1200baud 'B1':2400baud 'B2':4800baud 'B3':9600baud 'B4':19200baud 'B5':38400baud

4.4.4 Working Status Response Datasheet

The following table shows working status response datasheet.

Status	Code	Specification
Dispenser is ready	'0'(0x30)	Response this status while dispenser is waiting for command
Dispenser dispensing card	'1'(0x31)	Response this status while dispensing card
Last dispensing success	'3'(0x33)	Response this status while receive the first Enquiry command after card out
Dispensing error	'4'(0x34)	Response this status while dispensing error
Dispenser pre-dispense card	'5'(0x35)	Response this status while pre-dispense card
Dispense command can not be executed	'6'(0x36)	When stacker is empty of cards or error occurs on the dispenser, or dispenser is waiting for card being taken. Dispenser will not execute Dispensing command. Response this status after receive first Enquiry command.

	SPECIFICATION	Model No.	CRT-541
		Date	2010/01/10
	Card Dispenser	Ver.	1.0
		Page	9/16

4.4.5 Stacker Status Response Datasheet

The following table shows stacker status response datasheet.

Status	Code	Specification
Full of cards in stacker	'0'(0x30)	There are enough cards in stacker
Lack of card in stacker	'1'(0x31)	Card is not sufficient, please replenish cards
No card in stacker	'2'(0x32)	There is no card in stacker

Note: Data in parentheses is the hex value of matched ASCII.

4.5 TTL Communication Mode

4.5.1 Interface

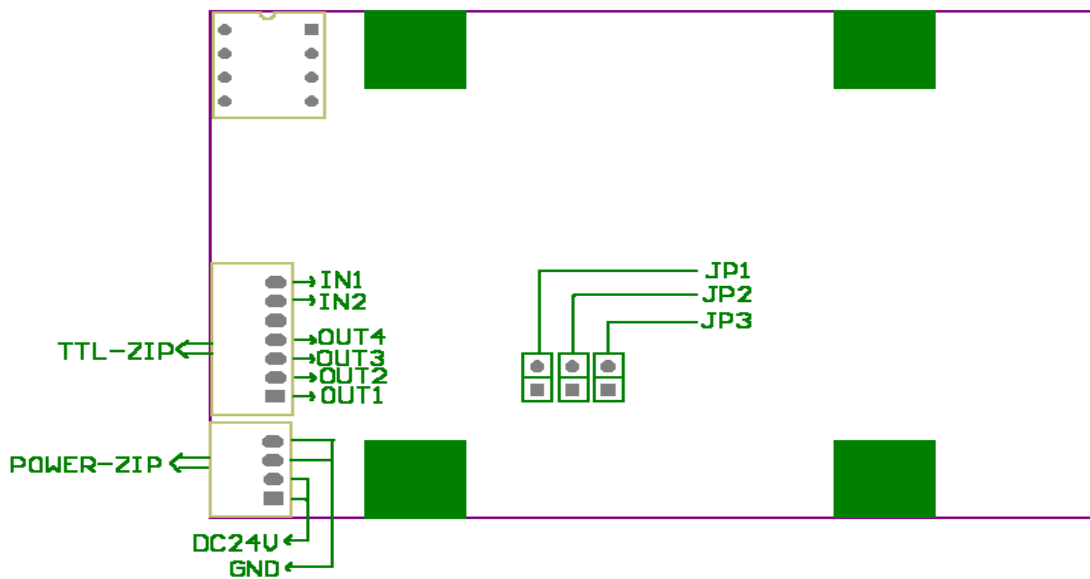

	SPECIFICATION	Model No.	CRT-541
		Date	2010/01/10
	Card Dispenser	Ver.	1.0
		Page	10/16

4.5.2 Pin Specification

Pin No.	SIGNAL	IN / OUT	ORIGINAL STATUS	AVAILABILITY STATUS
IN1	Dispensing card	IN	High“0V”	Low impulse (impulse width>100ms)
IN2	Reset	IN	High“0V”	Low impulse (impulse width>100ms)
OUT1	Error dispense	OUT	LOW“0V”	High “5V”
OUT2	Lack of card	OUT	LOW“0V”	High “5V”
OUT3	Card empty	OUT	LOW“0V”	High “5V”
OUT4	Card dispense success	OUT	LOW“0V”	High impulse (About100ms)
GND	ground			Ground

4.5.3 Communication Example

For dispensing card operation, the time interval for low impulse should at least 100ms

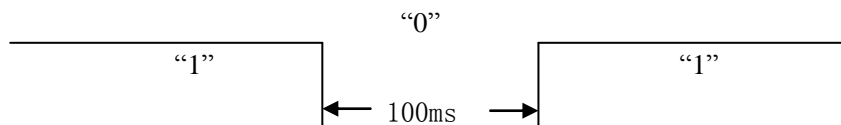

4.5.4 Jump Switch Specification

JP1, JP2, JP3: dispenser working mode choices

JP1: TTL mode while connection

JP2: Single version

JP3: Multi-units RS-232 mode

	SPECIFICATION	Model No.	CRT-541
		Date	2010/01/10
	Card Dispenser	Ver.	1.0
		Page	11/16

5. General Communication Process

- (1) After receiving correct data package, the unit will check the address. If matched, unit must give positive answer to host: ACK+ADDRESS (ADDRESS is the address of dispenser, 2 bytes); If not, unit can not send any data to the host.

The unit gives negative answer if received error response or BCC error: NAK+ADDRESS (ADDRESS is the address of dispenser, 2 bytes). If the address is not matched, data package cannot be re-sent by unit.

- (2) The host must re-send command package when connect with PC again after receiving negative response. If it is still not correct after several re-send, suggest the host alarm, and the user to check the communication circuit.
- (3) The host must not send nonexistent address number, otherwise, will not receive any response message.
- (4) The unit is subordinate to the host. Without receiving the command from the host, I t will not send any data to the host.

	SPECIFICATION	Model No.	CRT-541
		Date	2010/01/10
	Card Dispenser	Ver.	1.0
		Page	12/16

5.1 Typical Communication Process between Host & Unit

5.1.1 Normal process of dispensing

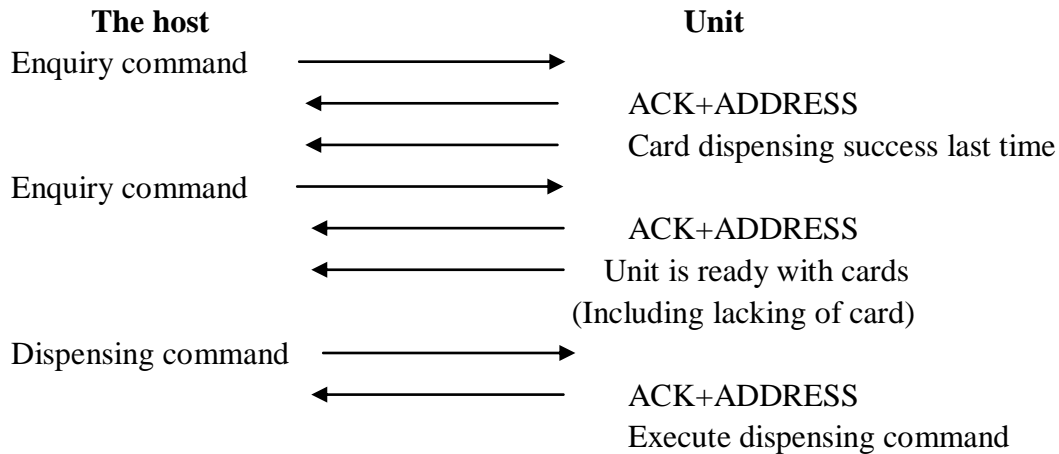

5.1.2 Received Dispensing Command

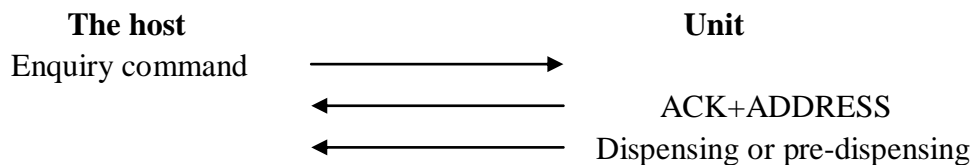

Waiting for a while (suggest >200ms)

Repeat above communication process till turn to 5.1.1 process

5.1.3 Received dispensing command while dispenser error

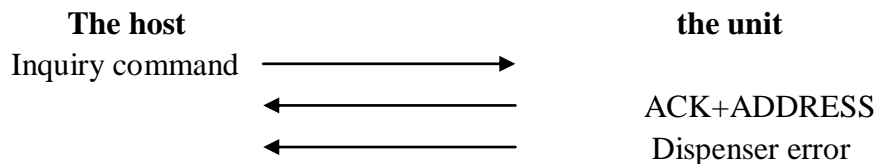

Waiting for a while (>200ms),

Repeat above communication process twice, suggest the host alarm error

Note:

- (1) The host should not communicate with another unit before the ending of communication with one unit to guarantee the communication fluency.
- (2) ACK+ ADDRESS is positive answer, ADDRESS is the address of dispenser, totally 2 bytes, sending high address byte first, then low address byte.
- (3) NAK + ADDRESS is negative answer, ADDRESS is the address of dispenser, totally 2 bytes, sending high address byte first, then low address byte.
- (4) For example: The response code is 0x06 0x30 0x31 while Unit No.1 give the host positive answer.

	SPECIFICATION	Model No.	CRT-541
		Date	2010/01/10
	Card Dispenser	Ver.	1.0
		Page	13/16

6. Multi-Unit Communication Setting

6.1 Sketch map of Multi-Unit PCB

The following diagram shows the PCB of Multi-Unit CRT-541.

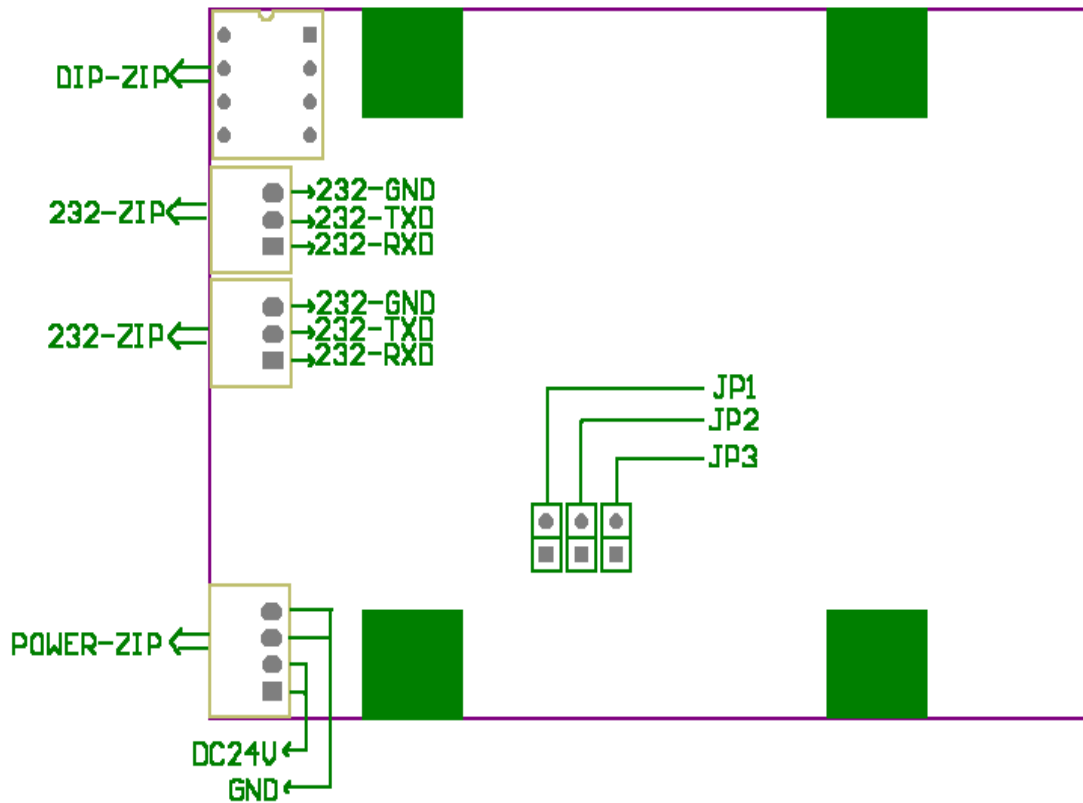

- Note: (1) 232-ZIP : Two RS232 interfaces complete the same. One connects to extension.
(2) DIP-ZIP: The multi-switch used to distribute the address of dispenser.

	SPECIFICATION	Model No.	CRT-541
		Date	2010/01/10
	Card Dispenser	Ver.	1.0
		Page	14/16

6.2 DIP Setting Of Unit Address

The following table shows the Dip setting of Unit Address.

Multi-switch				Corresponding address
4	3	2	1	
ON	ON	ON	ON	'00'
ON	ON	ON	OFF	'01'
ON	ON	OFF	ON	'02'
ON	ON	OFF	OFF	'03'
ON	OFF	ON	ON	'04'
ON	OFF	ON	OFF	'05'
ON	OFF	OFF	ON	'06'
ON	OFF	OFF	OFF	'07'
OFF	ON	ON	ON	'08'
OFF	ON	ON	OFF	'09'
OFF	ON	OFF	ON	'10'
OFF	ON	OFF	OFF	'11'
OFF	OFF	ON	ON	'12'
OFF	OFF	ON	OFF	'13'
OFF	OFF	OFF	ON	'14'
OFF	OFF	OFF	OFF	'15'

Note: Address default setting is '15'.

	SPECIFICATION	Model No.	CRT-541
		Date	2010/01/10
	Card Dispenser	Ver.	1.0
		Page	15/16

7. Maintenance And Cautions

7.1 Maintenance

After using for long time or dispensing amount of cards, the dispenser may be wearied out because of every part is running, so we need to do some maintenance to the machine. The steps as follows:

- 1) Check the parts of the dispenser. If they become loose or abnormal, tighten them.
- 2) Check the straps of drive wheels. If they become loose, calibrate the position of the elasticity wheel.
- 3) Use cleaning card or soft cloth with alcohol to clean the dispenser wheel in the bottom of the hopper and the drive wheel.
- 4) Use soft cloth with alcohol to clean the dirty cards and replace the distortion cards
- 5) Check the graduation of knob to see whether they are corresponding.

7.2 Cautions For Safe Use

- 1) Ensure the power is off while repairing the whole machine.
- 2) Notice the cathode and anode of the machine power while power on for the first time.
- 3) Notice the Specification of JUMP when using for the first time, because improper JUMP will cause work off or unpredictable status.
- 4) Prohibit to inset or pull out the receptacle of the port when power on. Otherwise, the circuit of the controller circuit may be spoiled
- 5) Ensure the dispenser out of smear. The smear will affect the capability of the dispenser.
- 6) On the back of dispenser side board, there is a red soft manual "Reset" keystroke. When error or abnormal situation occurs on spot, then engineer can press this keystroke for reset. It is not used in general situation.
- 7) Reset function: cards cleaning up in stacker and withdraw cards.
- 8) Reset over time protection: Motor will stop running to protect itself if pressing the Reset bottom for a long time.

	SPECIFICATION	Model No.	CRT-541
		Date	2010/01/10
	Card Dispenser	Ver.	1.0
		Page	16/16

7.3 WARRANTY

- 1) One year guarantee free of charge. Counting from the day that users receive the goods;
- 2) User sends the goods to us for repairing;
- 3) Provide after-sale service after exceeding guarantee period. We will take some material fee if need to replace fittings. And we will take some upkeep in the follows situations although it is in guarantee period;
 - a) Damage and trouble caused artificially;
 - b) Damage and trouble caused by non-professional operation;
 - c) Damage and trouble caused by instability of user's power supply;
 - d) Damage and trouble caused by force majeure, such as earthquake, natural weather etc.